

DONNA L. BRAUN
City Clerk-Treasurer
dbraun@northtonawanda.org

Lori Swartz
Assistant City Clerk

Denise Proefrock
Assistant City Treasurer

City of North Tonawanda

OFFICE OF THE CITY CLERK - TREASURER
VITAL STATISTICS
CITY HALL
216 PAYNE AVENUE
NORTH TONAWANDA, N.Y. 14120

Treasurer's Office: (716) 695-8575
Clerk's Office: (716) 695-8555
Fax: (716) 695-8557

July 14, 2022

The following meetings have been scheduled for TUESDAY, JULY 19, 2022:

6:15PM Common Council Discussion

6:30PM Common Council Meeting in the Common Council Chambers

Respectfully submitted,

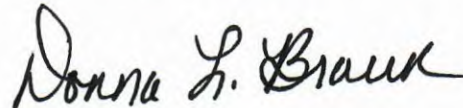

**Donna L. Braun
City Clerk-Treasurer**

**TO: Honorable Mayor & Common Council
Alderman Schmigel, DiBernardo, Lavey, Loncar, Pecoraro**

FROM: Donna L. Braun, City Clerk-Treasurer

RE: Agenda for Regular Session TUESDAY, JULY 19, 2022 6:30PM

AUDIENCE PARTICIPATION – Agenda items only, not to exceed 90 minutes with each speaker limited to a five-minute maximum.

PROOF OF PUBLICATION PUBLISHED 7/01/2022

- 1) Legal Notice – Completion of the City of North Tonawanda’s 2022 Final Assessment Roll – City Assessor**

COMMUNICATIONS FROM CITY OFFICIALS

- #1. Angela Johnson - Re: Resignation as Administrative Assistant**
- I. Mayor - Re: Appointment of Joyce Santiago as Administrative Assistant**
- VII. Accountant - Re: Payment of the Abstract of Claims Dated July 19, 2022**
- XIV. Youth, Recreation, Parks & Seniors - Re: Award of bid to Pump Irrigation Technology, for the Pump Station Upgrades at Deerwood Golf Course**
- XXV. Monthly Reports**
- .1 Clerk-Treasurer .2 Police Department .3 Senior Citizen Center**

XXXII.1 Dir. Community Development Re: Approval to hold a public hearing in the Common Council Chambers August 9, 2022, for the Community Development Block Grant Single Housing Rehabilitation program

XXXII.2 Dir. Community Development Re: Approval to Amend the Local Waterfront Revitalization Plan Budget, to submit five (5) Consolidated Funding Applications

COMMUNICATIONS FROM OTHERS

**A.
Oliver Street Merchants - Re: Permission to close Oliver Street between 9th and 11th Avenue for a “Labor Day” concert, Sunday, September 4, 2022**

**B.
Kim Larussa - Re: Permission to hold “Dogs are People, Too” event at Carruthers Park, Saturday September 3, 2022**

Respectfully submitted,

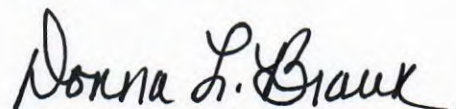

**Donna L. Braun
City Clerk-Treasurer**

STATE OF NEW YORK
NIAGARA COUNTY, } SS, _____

JUL 19 2022

Janet M. Slipko, of said county, being duly sworn, deposes and says that she is now and during the whole time hereinafter mentioned was the Clerk of

NIAGARA GAZETTE

A newspaper published in the County and State aforesaid,
and that the annexed printed legal # 301588
was printed and published in said paper on the following dates:

07/01/2022

Janet M. Slipko

Principal Clerk

Subscribed and sworn to before me this
7-5-22

Teresa L. McCarthy
Teresa L McCarthy 02/26/2026

Notary Public Expiration Date

RECEIVED
CITY CLERK'S OFFICE

2022 JUL 11 AM 8:29
NORTH TONAWANDA NY

TERESA L MCCARTHY
Notary Public - State of New York
No. 01MC4962698
Qualified in Niagara County
My Comm. Expires Feb. 26, 2026

Legal Notice
Completion of The
City of North Tonawanda's
2022 Final Assessment Roll

Notice is hereby given that the 2022 Final Assessment Roll for the City of North Tonawanda, New York, County of Niagara has been completed and verified pursuant to Section 516 of the Real Property Tax Law. It is on file in the office of the City Assessor. The Assessment Roll will also be in the North Tonawanda Public Library, Niagara County's Real Property Tax Service website: www.niagara-county.com/realproperty/ and City of North Tonawanda's website: <https://cityofntonawanda.prosgar.com>

Barbara W. Klenke
City Assessor
City of North Tonawanda, NY
N#301588

7/1/2022

#/.

JUL 19 2022

July 5, 2022

Mayor Austin J. Tylec
City of North Tonawanda
216 Payne Avenue
North Tonawanda, NY 14120

Dear Mayor Tylec,

Please accept this letter as my formal resignation from my Executive Assistant position, effective at the end of day, Friday, July 22, 2022.

I will assist with my replacement in any way I can to facilitate a smooth transition.

I have truly enjoyed working with you and representing our Office. Your dedication to North Tonawanda and moving it forward with better opportunities for everyone is noticeable and admirable. I am so honored to have been a small part of it. This city is in good hands, and I look forward to what is to come for North Tonawanda.

Thank you for giving me this opportunity.

Respectfully,

Angela

Angela R. Johnson

RECEIVED
CITY CLERK'S OFFICE
2022 JUL 14 AM 8:06
NORTH TONAWANDA NY

CITY OF NORTH TONAWANDA

I.

Office of the Mayor

JUL 19 2022

AUSTIN J. TYLEC

July 13, 2022

North Tonawanda Common Council
City Hall
216 Payne Avenue
North Tonawanda, NY 14120

RE: Appointment of Administrative Assistant

Dear Honorable Body,

Please be advised that I am appointing Joyce Santiago, 147 Eighth Avenue, North Tonawanda, NY 14120 as my Administrative Assistant effective on Tuesday, August 2, 2022.

Respectfully,

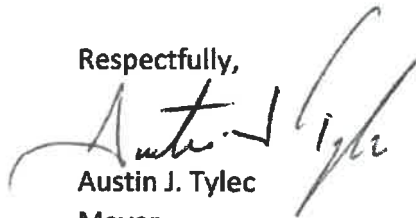
Austin J. Tylec
Mayor

2022 JUL 14 AMB:06
NORTH TONAWANDA NY

RECEIVED
CITY CLERK'S OFFICE

JEFFREY ZELLNER
CITY ACCOUNTANT

JENNIFER CRESS
PAYROLL PERSONNEL SPECIALIST

SHERI GAMPP
JUNIOR ACCOUNTANT

City of North Tonawanda

DEPARTMENT OF ACCOUNTING
CITY HALL
216 PAYNE AVENUE NORTH
TONAWANDA, N.Y. 14120

TELEPHONE: (716) 695-8545

FAX: (716) 695-8573

JUL 19 2022

July 14th, 2022

Honorable Austin J. Tylec, Mayor
And Common Council Members
City Hall
216 Payne Avenue
North Tonawanda, NY 14120

Dear Honorable Body:

In accordance with Article V, Division 1, Section 5.002 and 5.003 of the City Charter, an Abstract Sheet, comprised of a Warrant of Claims, has been submitted by this office for your review and approval.

Accordingly, please authorize for payment, the current Warrant of Claims for Common Council audit, dated July 19th, 2022, and further authorize the Mayor and City Clerk-Treasurer to respectively sign and countersign said Warrant.

Warm Regards,

JEFFREY ZELLNER
CITY ACCOUNTANT

2022 JUL 14 PM 12:22
NORTH TONAWANDA NY

RECEIVED
CITY CLERK'S OFFICE

NORTH TONAWANDA
Dept. of Youth, Recreation, Parks & Seniors

500 Wheatfield Street
North Tonawanda, NY 14120
Phone: (716) 695-8520
Fax: (716) 695-8533



www.ntparksrec.com

July 12, 2022

The Honorable Mayor Tylec and Common Council
216 Payne Avenue
North Tonawanda, New York 14120

After soliciting bids for the pump station upgrades at Deerwood Golf Course the following were the bid results.

BID RESULTS

Pump Irrigation Technology.... \$164,449.00
No other bids submitted

This is a very reputable company working on various pump stations at golf courses across the New York region. We are requesting approval to award the bid to Pump Irrigation Technology. Funds have been allocated through the capital account for Golf Course Improvements.

Respectfully Submitted,

Alex Domaradzki
Director of Youth, Recreation, Parks & Seniors

RECEIVED
CITY CLERK'S OFFICE

2022 JUL 19 AM 9:08
NORTH TONAWANDA NY

**BID PROPOSAL
DEERWOOD GOLF COURSE PUMP STATION UPGRADE
CITY OF NORTH TONAWANDA, NY 14120**

JOB TITLE: Deerwood Golf Course Pump Station Upgrade
JOB LOCATION: 1818 Sweeney Street, North Tonawanda NY 14120
REQUESTED BY: North Tonawanda Department of Youth, Recreation & Parks
BID SPECIFICATIONS: Proposal based of bid specifications in the bid solicitation. Due by 3pm July 12, 2022

VENDOR INFORMATION:

Company Name: Pump IRRIGATION TECH Phone: 716-818-4329

Address: 4647 MORNINGSIDE DR Contact Name: Sal Sgroi
EDEN NY 14057

Email: SALSGROI@PUMPIRRIGATIONTECH.COM

Total Bid Price: \$ 164,499.00

In your proposal be sure to include the following...

✓ **REFERENCES:**

Provide job descriptions from relatable golf course projects (minimum 3) completed by your company including date of each project, size of project, work completed, and reference information for contact.

✓ **PROPOSAL DESCRIPTION (INCLUDE ITEMIZED COSTS FOR LABOR & MATERIAL, ETC)**

If company standards differ from the repair and refinish specifications above, please provide a list of recommended procedural work to be expected by your company to complete the project to satisfactory conditions

✓ **PROPOSED JOB TIMELINE:**

Include proposed start date, and earliest potential completion date. Should there be reasons for not being able to meet this deadline (April 1, 2023) please provide details as to the earliest projected finish date.

2022 JUL 10 AM 10:51
CITY OF NORTH TONAWANDA

PROPOSAL ACCEPTANCE

I the undersigned herewith, propose to furnish the City of North Tonawanda, New York and the Department of Youth, Recreation & Parks, all items upon which we have bid for the prices herein, in accordance with the designated specifications.

The undersigned Bidder certifies to having read the instructions to bidders, the General conditions, the supplementary General Conditions (if applicable) and Non-collusive Bidding Certification and offers to furnish the articles specified to the Director of Youth, Recreation & Parks in the exact accordance with specifications and prices stated.

Non-collusive bidding certification. By submission of this bid proposal the bidder certifies that:

- (a) This bid proposal has been independently arrived at without collusion with any other bidder or with any competitor or potential competitor;
- (b) This bid proposal has not been knowingly disclosed and will not be knowingly disclosed, prior to the opening of bids for this project, to any other bidder, competitor or potential competitor
- (c) No attempt has been made or will be made to induce any other person, partnership or corporation to submit or not to submit a bid proposal.
- (d) The person signing this bid proposal certifies that he has fully informed himself regarding the accuracy of statements contained in this certification, and under penalties of perjury, affirms the truth thereof, such penalties being applicable to the bidder as well as the person signing its behalf;
- (e) That attached hereto (if a corporate bidder) is a certified copy of the resolution authorizing the execution of this certificate by the signatory of this bid proposal in behalf of the corporate bidder.

Total Bid Price: \$ 164,449.00

Authorized Representative Signature: 

Print Representative's Name: SAL Sgroi

Title of Representative: owner

Company Name: Pump IRRIGATION TECH

Mailing Address: 4647 MORNINGSIDE DR EDEN NY 14057

Telephone Number: 716-818-4329

Email Address: Salsgroie Pump IRRIGATIONTECH.com

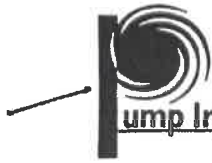

Pump Irrigation Technologies, Inc.

4647 Morningside Dr
Eden NY 14057

Quote

Date	Quote #
7/8/2022	719

Name / Address
Deerwood Golf Course Matt Borowiec 460 Wheatfield Rd N. Tonawanda, NY 14120

Job No.	Terms	PO NO.
	Net 30	Pump upgrade

Description	
<p>Labor - Scope of Work Remove existing 3 vertical turbine pump/motors and single existing pressure maintenance pump Remove existing 460 volt 3ph control panel Install New MCI UL Listed Control Panel - Need 460v 3ph 200amp Power in Building Install Panel, Pumps, Fabrication, wiring</p> <p>Materials - UL Control Panel with vertical turbine pumps/motors Standard MPC controls with single VFD drive and alternating contactors so each main motor may run XL or VFD. To run 3 40hp vertical turbine pumps and 1 3hp pressure Maint. pump. Built under ISO9001:2015 certification. MPC Standard Controls - Attachment Packet included Install 3 new 40hp vertical turbine pump/motors in existing locations Install new 3hp pressure maintenance pump in existing location Install new Data Industrial Flow meter and New Pressure transducer Install new Check valves Attachment packet included for 40hp's pump/motors Plumb in all pumps and fabricate to all Existing discharge piping Rebuild and reuse existing High pressure relief valve Wire in all components - Panel, Motors, Sensors</p> <p>Draw (Deposit) will be required to order the product</p>	
	Subtotal
	Sales Tax (8.0%)
	Total

Phone #
7168184329

E-mail	Web Site
salsgroi@pumpirrigationtech.com	pumpirrigation.com



Pump Irrigation Technologies, Inc.

4647 Morningside Dr
Eden NY 14057

Quote

Date	Quote #
7/8/2022	719

Name / Address
Deerwood Golf Course Matt Borowiec 460 Wheatfield Rd N. Tonawanda, NY 14120

Job No.	Terms	PO NO.
	Net 30	Pump upgrade

Description
<p>****IT MUST BE NOTED****</p> <p>This quote does not include a new fabricated skid because of the existing discharge height requirements and existing bored holes in the concrete slab floor. We will be using all existing discharge pipe and existing hole locations Unable to Source a 5hp pressure maintenance pump we had to go with a 3hp</p> <p>16-18 weeks Lead time Because of the Volatile nature of the market and pricing at this time we are unable to hold our pricing for 120 days Pricing will be held once order is placed unless otherwise stated.</p> <p>Proposed start date - Remove old components Late Fall of 2022. Install Spring of 2023 or sooner.</p>

Subtotal	\$164,449.00
Sales Tax (8.0%)	\$0.00
Total	\$164,449.00

To accept quote please call 716-818-4329
or E-mail SalSgroi@pumpirrigation.com

Phone #
7168184329

E-mail	Web Site
salsgroi@pumpirrigationtech.com	pumpirrigation.com

PROPOSAL

MPC Variable Speed Control Panel

Date: 7/8/22
To: Deerwood GC
Location: North Tonawanda, NY

Project: Panel/Pumps
Quotation: MCI07082022DEER
Quoted by: Sal Sgroi

Supply Power: 460/3/60
FTX#: 7278

PROPOSAL SCOPE

1 Ea. UL Listed Variable Speed Control Panel with Standard MPC controls with single VFD drive and alternating contactors so each main motor may run XL or VFD. Built under ISO9001:2015 certification.

MPC Standard Controls

- UL 508a Listed Control Panel
- Short Circuit Current Rating 100 ka
- NEMA 3R Enclosure
 - 3 Point Latch
 - Carbon Steel w/ Powder Coat Finish
- UL Listed heat exchanger
- 200-amp Main Fused Disconnect
- Type 1 Surge Protection w/status indicators
- Incoming Line Phase Monitor w/primary fusing
- PM Pump 3 HP
 - Class J fuses/block per contactor
 - AB Contactor w/1 AB SS OL per motor
- 3 Ea. Main Pump 40 HP
 - 1 Ea. 40HP Danfoss Aqua Drive w/high speed JKS fuse protection
 - 3 ½% DC Input Link Reactor
 - Door Mounted Keypad
 - DTW-272 40HP 6 Year Warranty on Danfoss VFD which includes coverage against damages from momentary line or load anomalies such as lightning strikes.
 - Class J fuses/block per contactor
 - AB Interlocked Contactors w/1 AB SS OL per main motor
- AB compactlogix PLC Platform
- AB 10" Panelview +7 Color HMI
- Inhand Network Switch with Modem

"Meeting our customers' requirements, every requirement, every time"

Jim Carter

- AB DC Power Supply
- AB "Full Size" 30 mm N4 Door Devices
 - Green Illuminated Switch per pump
 - System Switches: System Control, Low Discharge, VSD Bypass, PLC Bypass, Speed Pot and Red Illuminated Fault Push Button
- GFCI Outlet
- Control Power Transformer w/primary/secondary fusing
- Flow Signal Input: Pulse
- Lake Level Controls
 - HOA Selector Switch
 - PNR & Probes
- Fertigation Relay
- Safeties:
 - Low level shutdown
 - Low discharge pressure shutdown
 - High discharge pressure shutdown w/auto restart
 - VSD fault with auto restart
 - Solid State Overload shutdown per motor
 - Phase Failure, Imbalance and low voltage protection
- Operation Features
 - Lamp Test Function
 - Automatic alternation of pumps based on least run time
 - Intelligent Slow Ramp feature for automatic line fill
 - VFD Bypass
- 10" Color Touch screen interface
 - 3 Year Flow Total Logging Day/Week/Month/Year
 - Pump Run Times
 - Event Log
 - Flow and Station Trending
 - Assignable I/O
- MPC Remote Cell Monitoring w/1 Year Activation
- Remote pump station disable feature from any smart device or PC
- **Factory support remote access to PLC/HMI and VFD for programming and troubleshooting**
- **nSite, MCI's Cloud Based Solution NO SUBSCRIPTION FEE**
 - Scheduled monthly email with flow report in Excel format
 - Access to one full year of pressure, flow, alarms and event data
- **nAlert**
 - Manage maintenance due dates for all aspects of maintenance on your pumping station.
 - Warning light, display message and email alert when due.
 - Monitor and report irregular operation of irrigation system, pump system and filter system.

Instrumentation

"Meeting our customers' requirements, every requirement, every time"

Jim Carter

- SS Wika Pressure Transmitter 0-250 PSIG
- Pedestal for mounting enclosure

On Site set supervision, Start up and training included in pricing.

FOB: Dallas, Texas

Lead Time: 16-18 weeks following approved drawings

MCI Flowtronex reserves the right to substitute alternate products for any named brand products based on availability.

Additional Warranty items

- **Warranty Includes crane if needed**
- **6-year warranty on Variable frequency drive (Includes lightning damage coverage and labor to replace)**
- **6 Year Warranty on ALL COMPONENTS IN ELECTRICAL PANEL, Inclusive of power related damage such as lightning. Includes parts only.**

TERMS AND CONDITIONS OF SALE

All sales by and purchases from MOTOR CONTROLS INC., (Seller) are governed by the following terms and conditions:

1. All purchases and credits occurring after the closing date of a month will appear on the periodic statement for the next month. Payment shall be made to the Seller in U.S. currency at its offices in Dallas, Dallas County, Texas.
2. All purchase orders are subject to acceptance at Motor Controls Inc, Dallas, Texas. The following terms shall govern unless superseded by revised terms in the proposal body. Receipt of Production deposit, verification of acceptable credit and confirmation of design are required before production. On domestic orders deposit is required to initiate the order with the deposit due upon receipt. Deposit required to be determined based on credit analysis. For international orders, either an Irrevocable Letter of Credit (ILC) drawn on a U.S. Bank, with all costs of the ILC borne by the purchaser, is required for the full amount of purchase at time of order, or cash in advance.
3. In all cases if customer is unable to accept delivery once fabrication, assembly and testing are completed at the factory MCI shall invoice the total balance due. Customer shall agree to coordinate with MCI for storage arrangements and/or additional storage charges as deemed appropriate and necessary.
4. Late fee of 1.5% per month will be added to any balance due after thirty (30) days from the date of invoice. All payments and/or credits are applied to the outstanding balance before computing a finance charge.
5. All Orders shall be F.O.B. Dallas, Texas.
6. State, city and local taxes are excluded from the contract price unless otherwise noted. Sales tax will be invoiced on the contract price unless written exemption is provided.
7. Prices valid for 15 days from date of proposal unless otherwise noted.
8. Orders regularly entered, whether verbal or written, can only be cancelled in writing by the Buyer upon terms that will compensate the Seller against loss. Any additional paperwork furnished at the Buyer's request, such as sketches, drawings and specification sheets will be charged at Seller's cost.
9. Any claim for defects, damages or shortages of an order delivered must be made by the Buyer in writing and delivered to Seller within a period of ten (10) days after delivery. Failure to make such claim within the specified time constitutes an acceptance and admission that the order fully complies with the terms, conditions and specifications required. The Seller's liability shall be limited to the stated selling price of any defective goods and shall in no event include special or consequential damages, including profits (or

“Meeting our customers’ requirements, every requirement, every time”

Jim Carter



10661 Newkirk St.
Dallas, TX 75220
HQ 972.247.4440
FAX 972.247.8991

profits lost) or loss of use. Seller shall not be liable to buyer or any other person for any liability, loss, or damage caused or alleged to be caused, directly or indirectly, by the pumping package. Seller makes no warranty, whether express or implied, with respect to fitness for a particular purpose or merchantability of the pumping package or component

10. The Buyer bears the risk of loss of or damage to or destruction of the goods from the time of delivery. The Seller retains title to the goods until the Buyer pays the entire purchase price as specified plus any interest thereon. If requested by Seller, Buyer shall execute a security agreement and financing statement evidencing Seller's security interest in the goods delivered to Buyer
11. If the credit of Buyer in the judgment of the Seller becomes impaired at any time, the Seller has the right to require payment in advance before making further shipments, and to demand immediate performance of the Buyer of all obligations imposed upon him by this agreement.
12. If there is any breach of or default under this agreement and if the same is placed in the hands of an attorney for collection, or if collected by lawsuit or through the probate or bankruptcy court, or if any action of foreclosure be had hereunder, Buyer shall be liable for reasonable attorney's fees incurred by the Seller. In the event of default by Buyer, Seller may immediately proceed to enforce payment of Buyer's obligation and exercise all the rights and remedies provided by the Business and Commerce Code of the State of Texas, or the Uniform Commercial Code, as well as any other rights and remedies afforded to Seller by law. Should Buyer be in default, Seller may require Buyer to return all goods previously delivered to Buyer by Seller, and any subsequent expenses for retaking, holding, preparing for sale, and reselling of such goods shall be at Buyer's expense. Funds realized from such resale shall be credited to Buyer's unpaid account.
13. The Seller, or any credit bureau or investigating agency employed by the Seller, is hereby authorized to investigate the references herein listed or statements or other data obtained from the Buyer or from any other persons pertaining to the Buyer's credit or financial responsibility. The Buyer has read and understands the foregoing terms and conditions of this application for credit and has signed the same as an indication of intent to enter into an agreement with Seller for the future purchase of goods and services from time to time. The Buyer also understands that upon acceptance of this application by the Seller, this document constitutes an agreement between the Buyer and the Seller for payment of debts owed to the Seller in return for the delivery of goods ordered or performance of services requested by Buyer.
14. The terms herein contained shall be governed by the statutes of the State of Texas, and specifically the Business and Commerce Code of the State of Texas and the Uniform Commercial Code. In the event that any account owing by Buyer to Seller becomes delinquent, and legal proceedings are instituted for collection of said account or indebtedness, such legal proceedings may be instituted and prosecuted against Buyer and its guarantors, if any, in any Court in Dallas County, Texas, and the undersigned expressly agrees that venue for such proceeding shall be in Dallas County, Texas, even if the principal offices of the Buyer are located in another county within this state or outside of this state.
15. SELLER DISCLAIMS ANY WARRANTIES, EXPRESS OR IMPLIED, REGARDING THE MERCHANTABILITY OF THE GOODS DELIVERED TO BUYER NOR THE FITNESS OF SUCH GOODS FOR A PARTICULAR USE UNLESS A WRITTEN WARRANTY IS GIVEN TO BUYER BY SELLER AT TIME OF DELIVERY.
16. Seller warrants that the water pumping system or components will be free of defects in Materials and workmanship for 2 years from date of authorized start-up but not later than 27 months from date of invoice;

Provided that all installation and operation responsibilities have been properly performed and documented. Seller will provide a replacement part or component during the warranty life. Repairs done at Seller expense must be pre-authorized. Upon request, Seller will provide advice for troubleshooting the system.

This proposal contains equipment that may require costly means to remove or replace based on site conditions. Seller will not accept liability for costs associated with the removal or replacement of equipment in difficult to access locations. This includes but is not limited to the use of diving services, barges, helicopters, or other unusual requirements.

Default of any agreement with Seller or;

"Meeting our customers' requirements, every requirement, every time"

Jim Carter



10661 Newkirk St.
Dallas, TX 75220
HQ 972.247.4440
FAX 972.247.8991

- a. The misuse, abuse of the pumping package outside its intended use.
 - b. Failure to perform required maintenance service.
 - c. Pumping water not suitable for irrigation.
 - d. Exposure to electrolysis erosion.
 - e. Water salinity in excess of 2000 parts per million.
 - f. Water from a reverse osmosis plant without countermeasures in place.
 - g. Water with a Langelier Index less than -0.5 and greater than +1.5
 - h. Presence of destructive gaseous or chemical solutions in or around the packaged system.
17. The terms contained herein may be modified only by written agreement signed by Buyer and an officer of Seller, MOTOR CONTROLS INC.

Is this sale Taxable? (Circle one) YES NO

(If non-taxable please provide tax exempt certificate for the "ship-to" state)
Please fill out fields below and return all pages.

Accepted for Buyer: _____

Date: _____ Total Value with options: _____

Requested ship date: _____

Ship to Address: _____

Street address: _____

County _____ State _____ Zip _____

Contact Name: _____

Phone & Fax: _____ / _____

Email: _____

Cell Modem Acknowledgement

"Meeting our customers' requirements, every requirement, every time"

Jim Carter



10661 Newkirk St.
Dallas, TX 75220
HQ 972.247.4440
FAX 972.247.8991

MCI Flowtronex provides a state-of-the-art cell communication service designed to give the user premium functionality from anywhere that has an internet connection.

Our Remote Cell Monitoring Package includes the following features:

- The ability to provide a remote connection utilizing any smart phone, tablet, or PC that is capable of connection to the internet.
- nSite allows for flow report totals to be automatically emailed to the user once a month in an easy to use excel format.
- If the pump station has multiple flow zones the system will display flow totals for each zone in different tabs for more simple navigation.
- Remote management of the pump station includes performance tuning to each individual system's needs to further improve efficiency and reliability of our product.
- nAlert will send prompt notifications about maintenance due dates for all aspects on the pumping station along with alarm alerts.
- Free critical software updates to ensure you are getting the latest features and security.
- This agreement while in effect includes remote factory support at no additional cost to assist with the operation, troubleshooting, and tuning of the control system. This service often eliminates unnecessary service calls.
- Allows our support staff to access and troubleshoot 24/7 with full access to HMI, PLC and VFD from the MCI offices.
- Remote Training opportunities for new staff or refresher for existing staff.

These benefits are offered to you as long as the cell package is active. Your pump station includes one year of cell connection unless otherwise indicated. You will be invoiced for renewal 30 days prior to the end of your term. Invoice are net 30 days. Service shall be terminated for non-payment. If you chose to not renew please notify MCI Flowtronex. If service is terminated for any reason a reconnection fee of \$375 shall apply plus any un-paid balance. Cell communication is only available for intended use. Un-authorized connections are subject to additional charges.

Responsible Party Billing Information

Bill to Address: _____
 Street Address: _____
 County: _____ State: _____ Zip: _____
 Contact Name: _____
 Accounting Contact Name: _____
 Phone & Fax: _____ / _____
 Email: _____

Signature: _____

Next Renewal Rate (\$): _____
 Customer Email Address for VPN Token: _____

By signing above, I the signee, am acknowledging all the above information and understand that I will be billed after the end of the original terms of service then every 12 months.

Contact MCI To Pay by Credit Card

"Meeting our customers' requirements, every requirement, every time"
Jim Carter

OUTLINE DRAWING

Quote ID: TE 06 24 22 QTY: 1
DWT-CATM 10WAHC, 4 Stages

"J" DIA "K" PLCS
EQ SP ON "H" BC

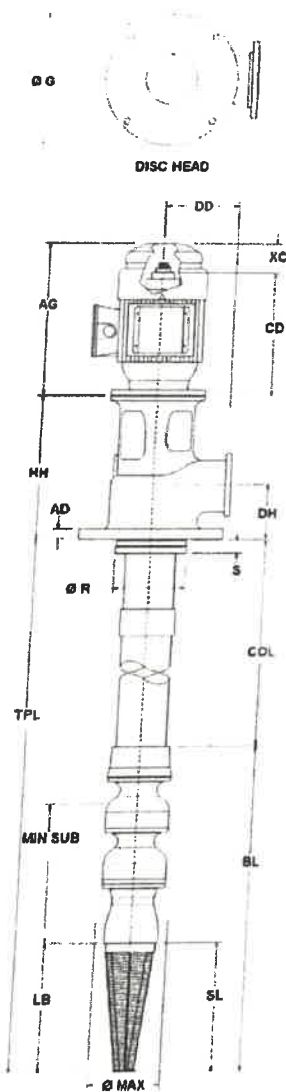

DIMENSIONS

Dim G [Mounting Flange Dia]:	23.50 in
J [Mounting Flange Hole Dia]	0.75 in
K [Mounting Hole Places]	4
H [Mounting Flange Bolt Circle]	21.25 in
Discharge Head Size	8.00 in
BD Head [Discharge Head Base Dia]	12.00 in
HH [Head Height]	17.50 in
AD [Mounting Flange Thickness]	1.88 in
DD [Disch Flange Stickout]	13.00 in
DH [Disch Flange Height]	7.50 in
S [Hanger Flange Stickdown Length]	2.06 in
R [Hanger Flange OD]	12.25 in
Column Length (COL)	169.54 in
COL [Column Diameter]	8.00 in
TPL [Total Pump Length]	228.00 in
MIN SUB [Minimum Submergence]	17.34 in
LB [Length to Bottom]	15.75 in
MAX [Max Assembly OD]	9.50 in
BL [Bowl Assembly Length]	58.48 in
SU [Shaft Stickup]	8.00 in
SL [Suction Length]	14.75 in
Discharge Flange	8"-125#
Suction Bowl Size	6"

PUMP DATA

Column Diameter	8 in [203 mm]
Lineshaft Diameter	1 3/16 in [30.2 mm]
Specified Flow	400.00 USgpm
Specified TDH	200.00 ft
Pumping Level	5.00 ft
Motor Manufacturer	
Driver Type	Vertical Hollow Shaft Motor
Motor Speed	1770 RPM
Phase / Frequency	

WEIGHTS

Total Bowl Weight	303 lbs
Total Column Weight	466 lbs
Head Weight	435 lbs
Motor Weight	NA lbs
Total Weight	1,204 lbs

NOTES

- Total Pump Length ± 1.0 Inch.
- Tolerance on all dimensions is .12 or ± .12 Inch per 5 ft, whichever is greater.
- All dimensions shown are in inches unless otherwise specified.
- Drawing not to scale.
- 1/2" NPT - Gauge Conn (plugged)
- Driver may be rotated at 90° intervals about vertical centerline for details refer to driver dimension drawing.
- Refer to product IOM for impeller setting requirements.
- This assembly has been designed so that its natural frequency responses avoid the specific operating speeds by an adequate safety margin. The design has assumed the foundation to be rigid.

DO NOT USE FOR CONSTRUCTION UNLESS CERTIFIED

Certified By	
Project	
Tag	
PO Number	
Serial Number	

CROSS SECTION DRAWING

Quote ID: TE 08 24 22 QTY: 1
 VIT-CATM 10WAHC, 4 Stages

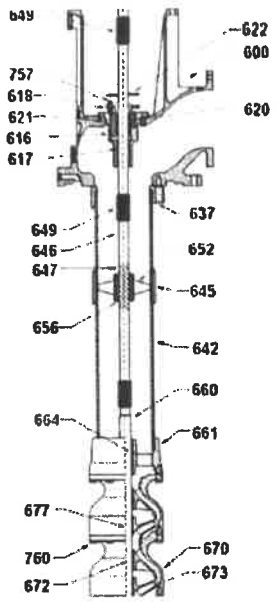

BILL OF MATERIALS				
ITEM	PART NAME	CODE	MATERIAL	ASTM#
Head Assembly				
608	Headshaft	2227	SST 416	A582 S41600
600	Head - Discharge	1003	Cast Iron CL 30	A48 CLASS 30B
604	Nut - Adjusting	2242	Carbon Steel 1018	A108
616	Box - Stuffing	1003	Cast Iron CL 30	A48 CLASS 30B
617	Bearing - Seal Housing	1618	Bismuth Bronze	B584 Modified
618	Gland - Split	1203	SST 316	A744M
620	Packing	6026	Graphite Packing	ML402-69
621	O-Ring	5302	Nitrile Buna N	D4322
622	Slinger	5121	Rubber EPDM	D3568
637	Flange - Column Hanger	1003	Cast Iron CL 30	A48 CLASS 30B
649	Coupling - Headshaft	2265	SST 416	A582M
730	Key - Motor Gib	2242	Carbon Steel 1018	A108
757	Screw - Gland Adj	2229	SST 316	A276
760	CapscREW - Hex	2298	Steel Bolting GR 8	J428
Column Assembly				
642	Pipe - Column	6501	Black Pipe Sch 40	A53
645	Column - Coupling	6501	Black Pipe Sch 40	A53
646	Lineshaft	2227	SST 416	A582 S41600
649	Coupling - Lineshaft	2265	SST 416	A582M
652	Retainer - Bearing	1205	SST 304	A744M
656	Bearing - Lineshaft	5121	Rubber EPDM	D3568
Bowl Assembly				
660	Bowlshaft	2227	SST 416	A582 S41600
661	Bowl - Discharge	1003	Cast Iron CL 30	A48 CLASS 30B
664	Bearing - Discharge Bowl	1618	Bismuth Bronze	B584 Modified
670	Bowl - Intermediate	6911	Cast Iron CL 30 Enamel	A48
672	Bearing - Intermediate Bowl	1618	Bismuth Bronze	B584 Modified
673	Impeller	1203	SST 316	A744M
677	Taperlock - Impeller	2242	Carbon Steel 1018	A108
688	Suction	1003	Cast Iron CL 30	A48 CLASS 30B
690	Bearing - Suction	1618	Bismuth Bronze	B584 Modified
692	Sandcollar	1205	SST 304	A744M
698	Strainer	6952	Carbon Steel Galv	A123M
747	Plug - Pipe	1046	Malleable Iron	A197
760	CapscREW - Hex	2298	Steel Bolting GR 8	J428

DO NOT USE FOR CONSTRUCTION UNLESS CERTIFIED	
Certified By	
Project	
Tag	
PO Number	
Serial Number	

PERFORMANCE CURVE

Quote ID: TE 06 24 22 QTY: 1
 VIT-CATM 10WAHC, 4 Stages

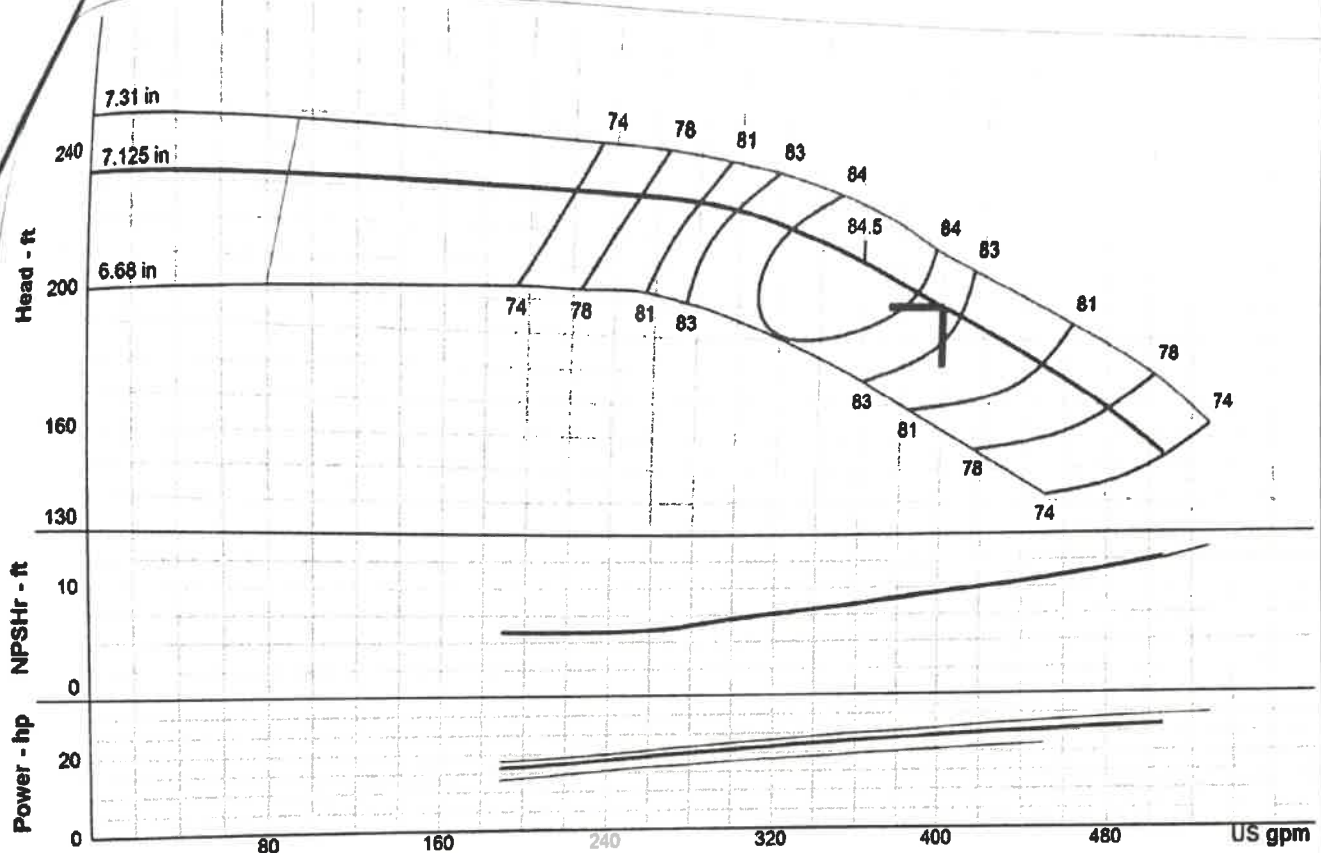

Curve & hydraulic data presented is nominal performance based on ANSI/HI 14.6 acceptance grade 2B.
 Design values are guaranteed within the following tolerances: Flow \pm 8%, Head \pm 5%, and optionally either Power + 8% or Efficiency - 5% at manufacturer's discretion.

Specified Flow	400.00 USgpm	Shut Off TDH (Disch Flange)	227.4 ft	Driver Size Criteria	NOL Power Across Design Curve
Specified TDH	200.00 ft	Shut Off Pressure (Bowl)	100.9 psi	Allow Service Factor	No
Rated Speed	1770 RPM	Shut Off Pressure (Disch Flange)	86.6 psi	kWh per 1000 gal	0.00000
Atmospheric Pressure	14.70 psi	Run Out Flow	506.0 USgpm	NPSHr at Design	9.6 ft
Pumping Level	5.00 ft	Run Out TDH (Bowl)	155.0 ft	NPSH Margin at Design	36.8 ft
NPSHa at Grade	34.0 ft	Run Out TDH (Disch Flange)	148.0 ft	Min Submergence at Design	17.34 in
NPSHa at 1st Impeller	46.3 ft	Run Out Pressure (Bowl)	67.1 psi	Actual Submergence	162.87 in
Fluid	Water	Run Out Pressure (Disch Flange)	64.1 psi	Thrust K-Factor	4.7 lbpft
Fluid Temperature	68.0 °F	Bowl Efficiency at Design	83.30 %	Thrust at Design	1098.2 lb
Specific Gravity	1.0000	Guaranteed Bowl Efficiency	NA %	Thrust at Shut Off	1262.6 lb
Viscosity	1.0017 cP	Best Efficiency	84.50 %	Thrust at Run Out	674.4 lb
Vapor Pressure	0.3383 psi	BEP Flow	360.0 USgpm	Bowl Material	Cast Iron with Glass Enamel
Density	62 lbs/ft ³	Design Flow % BEP	111.11 %	Bowl Material Derate Factor	1.00
Design Flow	400.0 USgpm	Pump Efficiency	82.40 %	Impeller Material	316SS
Min Flow (MCSF)	90.1 USgpm	Friction Loss at Design	0.13 ft	Impeller Matl Derate Factor	1.00
Design TDH (Bowl)	200.0 ft	Power at Design	24.2 Hp	Total Flow Derate Factor	1.00
Design TDH (Disch Flange)	194.2 ft	Guaranteed Power	NA Hp	Total Head Derate Factor	1.00
Design Pressure (Bowl)	86.6 psi	NOL Power	26.7 Hp	Total Efficiency Derate Factor	1.00
Design Pressure (Disch Flange)	84.1 psi	Max Power (NOL) Flow	506.0 USgpm		
Shut Off TDH (Bowl)	233.0 ft	Recommended Power	30.00 Hp		

DO NOT USE FOR CONSTRUCTION UNLESS CERTIFIED

Certified By	
Project	
Tag	
PO Number	
Serial Number	

PUMP DATA SHEET Turbine 60 Hz

Company: ITT Goulds Pumps
 Name:
 Date: 05/11/07

*EXISTING
 MIDDLE
 PUMP
 FOR
 REFERENCE*



Pump:

Size: 10WAHC (4 stages)
 Type: Lineshaft
 Synch speed: 1800 rpm
 Curve: E6410WAPC1
 Specific Speeds: Ns: 1695
 Pump Notes for Standard Sizes:
 Suction Size-6" Discharge Sizes-4",6",8"
 Vertical Turbine:
 Bowl size: 9.5 in
 Max lateral: 0.63 in
 Thrust K factor: 4.65 lb/ft

Search Criteria:

Flow: 400 US gpm
 Head: 200 ft
 Fluid: Water
 SG: 1
 Viscosity: 1.105 cP
 NPSHa: --- ft
 Temperature: 60 °F
 Vapor pressure: 0.2563 psi a
 Air pressure: 14.7 psi a

Motor:

Standard: NEMA
 Size: 30 hp
 Speed: 1800

Pump Limits for Standard Construction:

Temperature: 120 °F
 Sphere size: 0.45 in
 Pressure: 375 psi g

Sizing criteria: Max Power on Design Curve

— Data Point —
 Flow: 400 US gpm
 Head: 200 ft
 Eff: 83.4%
 Power: 24.2 hp
 NPSHr: 9.52 ft

— Design Curve —
 Shutoff Head: 233 ft
 Shutoff dP: 101 psi
 Min Flow: --- US gpm
 BEP: 84.5% eff
 @ 360 US gpm
 NOL Pwr: 26.7 hp
 @ 506 US gpm

— Max Curve —
 Max Pwr: 29.5 hp
 @ 529 US gpm

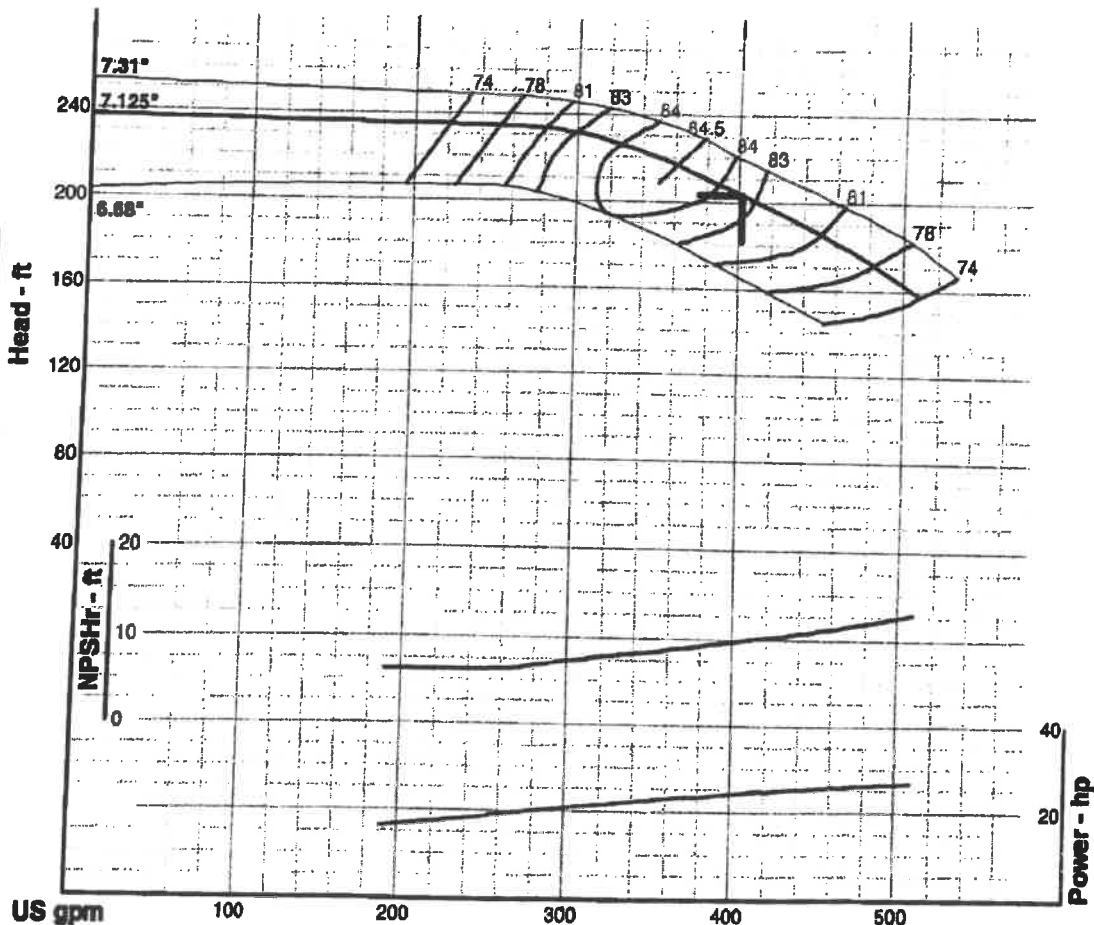

Performance Evaluation:

Flow US gpm	Speed rpm	Head ft	Pump %eff	Power hp	NPSHr ft
480	1770	169	78	26.2	11.7
400	1770	200	83.4	24.2	9.52
320	1770	224	83.8	21.5	7.62
240	1770	231	76.5	18.2	6.06
160	1770	---	---	---	---

Customized Drawing for SO: 529793
Date: 9-11-07
Authorized by: Steve DeVore

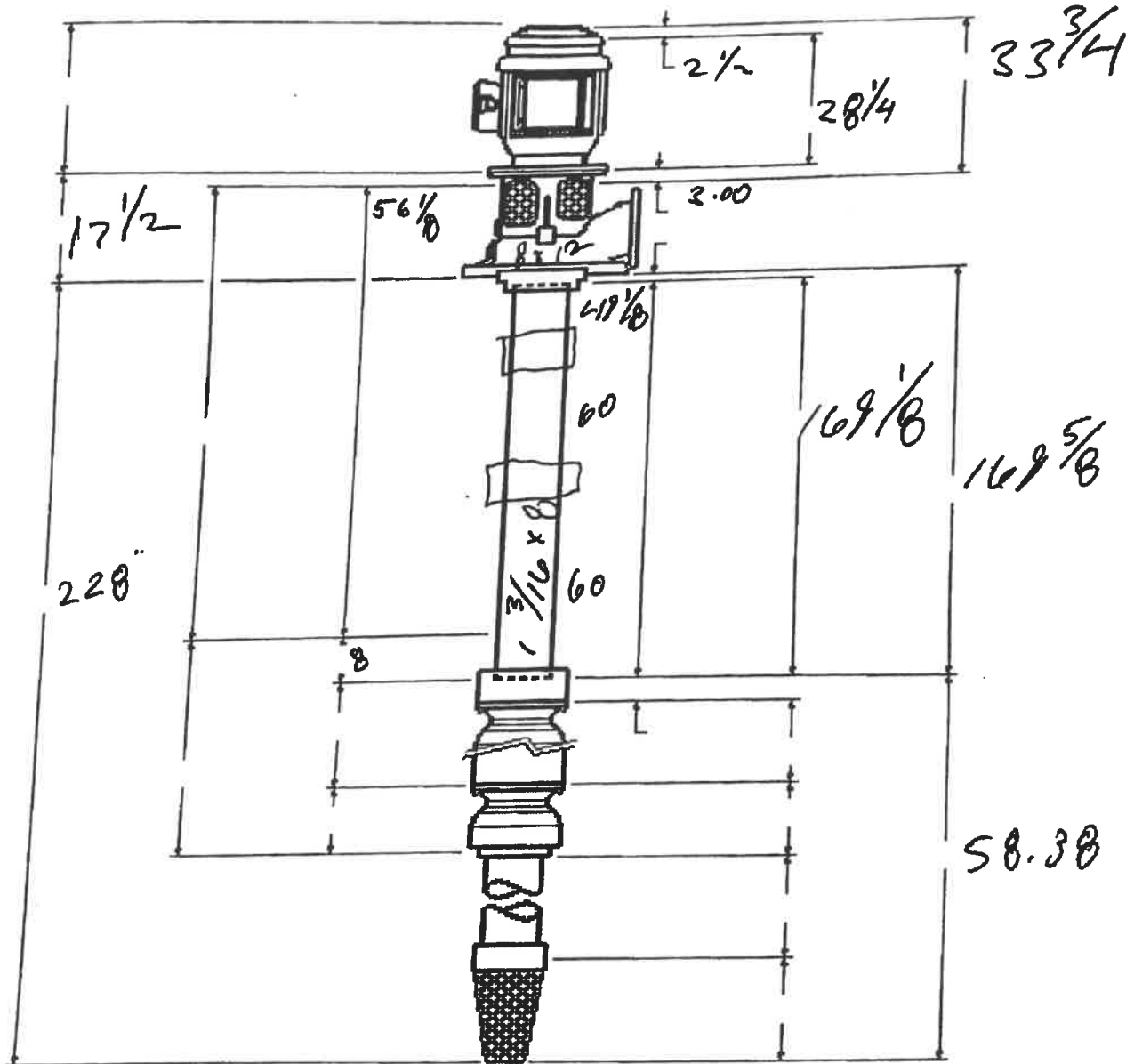

DWT-CT Layout



Pump Irrigation Technologies, Inc.
COMPLETE GOLF COURSE SERVICE

4647 Morningdale Drive • Eden, NY 14057 • (716) 818-4329 office
Email: sales@PumpIrrigation.com

References

Durand Eastman – New MCI Station 2022
Arrowhead Golf Course – New MCI Station 2021
Transit Valley Country Club – New MCI Station 2021
Stafford Country Club – New MCI Station 2020
Greystone Country Club – New Station 2020
Orchard Park Country Club – New MCI Station 2018
Drumlins Golf Course – New MCI Retro-Panel 2020
East Aurora Country Club – New MCI – Retro-Panel 2019
Twin Hills Country Club – New MCI Retro-Panel 2021

XXX-1
JUL 19 2022

Account#	Account Description	Fee Description	Qty	Local Share
A1255	Minor Sales	Certified Copies - Marriage	10	100.00
		Sub-Total:		\$100.00
A1550	Minor Sales	Public Pound Fee	1	25.00
		Sub-Total:		\$25.00
A1603	Misc. Fees	Birth Certificates	51	510.00
		Death Certificates	43	430.00
		Deaths Recorded	14	0.00
		Free Death Certificates	1	0.00
		Geneology Death	3	33.00
		Geneology Search	1	11.00
		Sub-Total:		\$984.00
A1980	Minor Sales	City Market	4	380.00
		Sub-Total:		\$380.00
A2110	Planning & Zoning Fees	Board of Appeals App.	2	100.00
		Planning - Rezoning	4	400.00
		Sub-Total:		\$500.00
A2410	Minor Sales	Boathouse 2022	10	11,124.50
		Sub-Total:		\$11,124.50
A2501	Minor Sales	Solicitors Permit - Yearly	6	150.00
	Permit Fees	Food Truck	1	100.00
		Sub-Total:		\$250.00
A2505	Marriage License Fee	Marriage License Fee	21	367.50
		Sub-Total:		\$367.50
A2506	Conservation	Conservation	16	43.66
		Sub-Total:		\$43.66
A2540	Racing & Wagering Fees	Bingo Proceeds	5	161.15
		Sub-Total:		\$161.15
A2542	Dog Licensing	Exempt Dogs	1	0.00
		Female, Spayed	107	963.00
		Female, Unspayed	10	170.00
		Male, Neutered	77	693.00
		Male, Unneutered	13	221.00
		Sub-Total:		\$2,047.00
A2610	Minor Sales	Parking Tickets	21	1,735.00
		Sub-Total:		\$1,735.00

RECEIVED
CITY CLERK'S OFFICE
2022 JUL 1 11:43 AM
CITY CLERK'S OFFICE

Account#	Account Description	Fee Description	Qty	Local Share
			Total Local Shares Remitted:	\$17,717.81
Amount paid to:	New York State Department of Health			472.50
Amount paid to:	NYS Ag. & Markets for spay/neuter program			253.00
Amount paid to:	NYS Environmental Conservation			746.34
Total State, County & Local Revenues:		\$19,189.65	Total Non-Local Revenues: \$1,471.84	

Pursuant to Section 27, Sub 1, of the City Law, I hereby certify that the foregoing is a full and true statement of all fees and monies received by the City Clerks Office, City of North Tonawanda, during the period stated above, in connection with my office, excepting only such fees and monies, the application of which are otherwise provided for by law.

Donna L. Brauer

City Clerk-Treasurer

7/1/22

Date

City of North Tonawanda

DONNA L. BRAUN
City Clerk-Treasurer
dbraun@northtonawanda.org

Lori Swartz
Assistant City Clerk

Denise Proefrock
Assistant City Treasurer

OFFICE OF THE CITY CLERK - TREASURER
VITAL STATISTICS
CITY HALL
216 PAYNE AVENUE
NORTH TONAWANDA, N.Y. 14120

XXV, 1

Treasurer's Office: (716) 695-8575
Clerk's Office: (716) 695-8555
Fax: (716) 695-8557

JUL 19 2022

RECEIVED
CITY CLERK'S OFFICE

2022 JUL 8 PM 2:01
NORTH TONAWANDA, NY

7/8/2022

Honorable Mayor & Common Council
216 Payne Avenue
North Tonawanda, NY 14120

Dear Sirs:

The status of the City of North Tonawanda accounts is reflected by this cash statement for the month of June 2022.

General Fund

Balance Fwd - Checking	9,503,590.71
Balance Fwd - Money Market	3,000,268.89
Investments	(5,000,000.00)
Receipts for the month	1,959,367.13
Warrants Drawn	(3,081,268.69)
	<u>\$6,381,958.04</u>

Sewer Fund

Balance Fwd - Checking	11,674.00
Balance Fwd - Money Market	8,858.87
Investments	0.00
Receipts for the month	707,734.12
Warrants Drawn	(288,719.77)
	<u>\$439,547.22</u>

Water Fund

Balance Fwd - Checking	1,137,403.70
Balance Fwd - Money Market	1,239,148.98
Investments	0.00
Receipts for the month	480,960.83
Warrants Drawn	(202,474.35)
	<u>\$2,655,039.16</u>

Trust & Agency Fund

Balance Fwd - Checking	277,492.44
Receipts for the month	34,262.57
Warrants Drawn	(28,563.49)
	<u>\$283,191.52</u>

Capital Construction Fund

Balance Fwd - Checking	4,252,087.34
Balance Fwd - Money Market	5,011,707.27
Receipts for the month	433,216.45
Warrants Drawn	(964,253.95)
	<hr/>
	\$8,732,757.11

Community Development Fund

Balance Fwd - Chccking	1,193,950.87
Receipts for the month	80,342.28
Warrants Drawn	(80,342.28)
	<hr/>
	\$1,193,950.87

Rental Assistance Fund

Balance Fwd - Checking	0.00
Receipts for the month	221,918.00
Warrants Drawn	(221,918.00)
	<hr/>
	\$0.00

Housing Rehabilitation Fund

Balance Fwd	1,476.26
Receipts for the month	0.01
Warrants Drawn	0.00
	<hr/>
	\$1,476.27

Home Rehabilitation Fund

Balance Fwd	40,683.56
Receipts for the month	0.00
Warrants Drawn	0.00
	<hr/>
	\$40,683.56

Respectfully submitted,

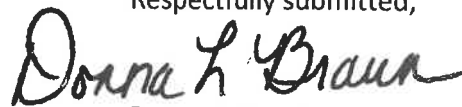

Donna L. Braun
City Clerk-Treasurer



Department of Police

CITY OF NORTH TONAWANDA
216 Payne Avenue
North Tonawanda, N.Y. 14120-5491

XV. 2

TELEPHONE
(716) 692-4111
FACSIMILE
(716) 692-4321
EMERGENCY NO.
9-1-1

JUL 19 2022

July 5, 2022

Honorable Mayor Austin J. Tylec and
Members of the City of North Tonawanda Common Council

Dear Sirs,

Please find the attached Summary of Police Activities Report, the Summary of Criminal Activities Report and the V&T Report for the month of May 2022

Respectfully Submitted,

Keith T. Glass
Chief of Police

cc: Robert Pecoraro
cc: Joe Loncar
cc: Robert Schmigel
cc: Frank DiBernardo
cc: Joseph Lavey Jr.

KTG/as

NORTH TONAWANDA POLICE DEPARTMENT SUMMARY OF POLICE ACTIVITIES FOR THE MONTH OF MAY 2022

CRIMINAL

Complaints received and investigated	87
Complaints cleared by arrest or exceptional clearance	35
Complaints ruled unfounded	0
Number of males arrested	22
under 18:	1
over 18:	21
Number of females arrested	12
under 18:	0
over 18:	12
Arrests for other authorities	0
Failure to Appear/Violation of Probation Warrant Arrests	26
Above complaints cleared by J.A.B.	15
Complaints cleared by J.A.B. from previous months	7

TRAFFIC

Traffic summonses issued	1014
DWI arrests	14
Parking tags issued	35

MISCELLANEOUS

Miscellaneous service	2,657
Incident reports	110
Vehicle accidents	37
Vehicle accidents (fatal)	0
Vehicle stops	687
Police escorts	0
Prisoner meals	0
Mug shots taken	50
Fingerprints taken	50
Persons missing and located	2
Automobiles stolen	1
Automobiles recovered	1
Automobiles recovered for other authorities	0
Record check fees	\$135.00
Photocopy fees	\$2.50
Fingerprint fees	\$0.00
Fines collected	\$50,005.00
Value of property damaged	\$1,581.00
Value of property stolen	\$72,226.75
Value of property recovered	\$30,000.00

Respectfully submitted,



Keith T. Glass
Chief of Police

KTG/as

NORTH TONAWANDA POLICE DEPARTMENT SUMMARY OF CRIMINAL ACTIVITIES FOR THE MONTH OF MAY 2022

CRIMINAL FELONIES, MISDEMEANORS AND OFFENSES

<u>TYPE OF OFFENSE</u>	<u>COMPLAINTS</u>		
	Received	Cleared	Unfounded
AGG. ASSAULT	5	3	
ALL OTHER OFFENSES	16	13	
ARSON	0	0	
BURGLARY	2	1	
COERCION	0	0	
CRIMINAL MISCHIEF	5	4	
CRIM POSS WEAPON	0	0	
DIS CON/HARASS	18	8	
DRUG OFFENSES	4	1	
EMBEZZLEMENT	0	0	
FAILURE TO APPEAR	26	26	
FORGERY	1	0	
FRAUD (ID THEFT)	3	1	
LARCENY	21	3	
LEAVING THE SCENE	4	1	
MURDER	0	0	
RAPE	0	0	
ROBBERY	0	0	
SEXUAL OFFENSES	3	0	
SIMPLE ASSAULT	3	1	
STOLEN PROPERTY	1	0	
UNAUTH USE M/V	1	0	
VIOL OF PROBATION	0	0	
ARRESTS FOR OTHER AUTHORITIES		0	
ARRESTS/CLEAR COMPS. FM PREV MONTHS		5	
TOTALS	113	67	
# OF ABOVE COMPLAINTS CLEARED BY JAB		15	
# CLEARED BY JAB FROM PREV MONTHS		7	

V & T REPORT FOR THE MONTH OF MAY 2022
--

TRAFFIC INFRACTIONS:	
SPEEDING	404
REDLIGHT VIOLATION	43
STOP SIGN VIOLATION	150
NO REGISTRATION	15
NO LICENSE	35
FAULTY EQUIPMENT	38
NO INSPECTION	65
FAILED TO YIELD RIGHT OF WAY	6
SEAT BELT VIOLATION	54
NO INSURANCE	5
LICENSE PLATE VIOLATION	12
IMPROPER TURN	11
DROVE ON LEFT SIDE OF PAVEMENT MARKINGS	7
FAILED TO KEEP RIGHT	0
LEAVING SCENE OF INCIDENT	1
FAILURE TO SUBMIT TO PRE-SCREEN BREATH TEST	5
AVOIDING INTERSECTION OR TRAFFIC CONTROL DEVICE	0
FAILURE TO NOTIFY COMMISSIONER OF CHANGE OF ADDRESS	7
UNSAFE BACKING	0
MISCELLANEOUS	<u>62</u>
TOTAL	<u>920</u>

TRAFFIC MISDEMEANORS:	
DWI	17
OPERATING WHILE REGIS. SUSPENDED/REVOKED	9
AGGRAVATED UNLICENSED OPER 3RD	39
AGGRAVATED UNLICENSED OPER 2ND	14
RECKLESS DRIVING	1
LEAVING SCENE INJURY ACCIDENT	0
DISPLAY FORGED CERTIFICATE W/O INSPECTION	2
OPER MV WHEN LICENSE/REGISTRATION IS SUSPENDED	1
FAILURE TO SURRENDER SUSP/REVOKED LICENSE/REGIS	0
USE/LEASE/RENTED/LOANED VEHICLE W/O INTERLOCK DEVICE	<u>2</u>
TOTAL	<u>85</u>

TRAFFIC FELONIES:	
AGGRAVATED UNLICENSED OPERATION 1ST	3
AGGRAVATED DWI/CHILD IN VEHICLE	1
DWI/PREVIOUS CONVICTION W/IN 10 YEARS	5
DRIVING W/ABILITY IMPAIRED BY DRUG(SPECIAL)	0
DRIVING W/ABILITY IMPAIRED BY DRUG(FELONY)	<u>0</u>
TOTAL	<u>9</u>

FINES:	(CITY IMPOSED)		
		TRAFFIC	\$48,255.00
		PENAL LAW	\$0.00
		CITY ORDINANCE	\$0.00
		BAIL FORFEITURE	\$0.00
		PARKING TAGS	\$1,750.00
		TOTAL	\$50,005.00

MUG SHOTS: 50 PARKING TAGS: 35 MEAL TICKETS: 93

NORTH TONAWANDA
Dept. of Youth, Recreation, Parks & Seniors

500 Wheatfield Street
North Tonawanda, NY 14120
Phone: (716) 695-8520
Fax: (716) 695-8533



www.ntparksrec.com

July 6, 2022

The Honorable Mayor Austin Tylec
And Common Council
216 Payne Avenue
North Tonawanda, New York 14120

Ladies and Gentlemen:

The following information is submitted for your perusal concerning participants in various programs offered at the Senior Citizen Center for the month of June 2022

Senior Center's Total Monthly Services 2,178

Unduplicated 748

Duplicated 1,430

Please note: We also sponsor a "Little Free Food Pantry" and a "Little Library" both of these are available to the public 24/7 and is not included in this monthly count.

Sincerely,

Pamela A. Hogan

Recreation & Senior Coordinator

2022 JUL 7 PM 12:45
NORTH TONAWANDA NY

RECEIVED
CITY CLERK'S OFFICE



City of North Tonawanda

Department of Community Development
500 Wheatfield Street
North Tonawanda, New York 14120
716-695-8580
716-614-0519 (fax)

XXXII.1

JUL 19 2022

July 12th, 2022

Honorable Mayor and City Council
City Hall
216 Payne Avenue
North Tonawanda, NY 14120

Re: Community Development Block Grant Program – Request for Public Hearing

Dear Honorable Body,

In consideration of a possible application to the New York State Office of Community Renewal Community Development Block Grant Single Family Housing Rehabilitation Program, per CDBG regulations, the City of North Tonawanda is required to hold a public meeting to discuss CDBG activities and the potential application. The hearing must be held at a meeting with a quorum of the Common Council.

I would like to formally request authorization to hold a required public meeting for the Community Development Block Grant Single Family Housing Rehabilitation program to be held on **August 9th, 2022**, at 6:00pm in the Common Council chambers immediately preceding the regularly scheduled Common Council workshop meeting.

Thank you for your time and consideration.

Kindest regards,

Laura Wilson
Director

RECEIVED
CITY CLERK'S OFFICE
2022 JUL 12 PM 3:49
NORTH TONAWANDA NY



City of North Tonawanda

Department of Community Development
500 Wheatfield Street
North Tonawanda, New York 14120
716-695-8580
716-614-0519 (fax)

XXXII.2

JUL 19 2022

Honorable Mayor and City Council
216 Payne Avenue
North Tonawanda, NY 14120

Re: 2022 New York State Consolidated Funding Application- Local Waterfront Revitalization Plan Budget Amendment

Dear Honorable Body,

As you are aware, on July 5th 2022 at the regular session of the North Tonawanda Common Council meeting, the Common Council passed a resolution allowing the City to submit five (5) Consolidated Funding Applications (CFAs) to various State agencies for the following projects:

- Comprehensive Plan Update
- Memorial Pool- Pre-Planning Development & Design
- Gateway Harbor Wifi & Harbor Master Facility Technology Improvements
- Local Waterfront Revitalization Plan update
- Wastewater Treatment Plant- Green Infrastructure Grant Program (GIGP)

Upon review of the passed resolution, the budget for the Local Waterfront Revitalization Plan (LWRP) update will need to be amended as the total project cost and match requirements have changed:

Local Waterfront Revitalization Plan (LWRP) Update:

The City of North Tonawanda is looking to update its Local Waterfront Revitalization Plan (LWRP) which has not been updated since 1988. The LWRP plan provides a long-term land and water use plan and identifies legal techniques and policies for implementation. The LWRP plan guides future development along the waterfront and includes general regulations such as: assuring that new waterfront development is well designed, provides public access, brings land use regulations into better conformity while protecting natural areas and reducing the impact on our environment and waterways. Once in place, the LWRP will be utilized to better compete for waterfront development projects and should be reviewed and reaffirmed by the Common Council at least once every five years.

2022 JUL 19 PM 12:09
NORTH TONAWANDA NY

RECEIVED
CITY CLERK'S OFFICE
RECEIVED
CITY CLERK'S OFFICE

The minimum award for the LWRP update is \$50,000 with a 25% match requirement. The City of North Tonawanda is eligible for a reduced 15% match because of its location in an Environmental Justice area.

New Budget Breakdown:

NYS LWRP Program:	\$130,000
Local Match (15%)*:	\$23,000.00 (\$10,000 In Kind/ \$13,000 Cash)
Total Project Cost:	\$153,000

Original Budget Breakdown (approved 7/5/22):

NYS LWRP Program:	\$97,500
Local Match (25%):	\$32,500 (\$10,000 In Kind/ \$22,500 Cash)
Total Project Cost:	\$130,000

*since the July 5th 2022 Common Council approval, guidance has been provided by the New York State Department of State that North Tonawanda is eligible for 15% match due to its location in an Environmental Justice area.

At this time I would like to respectfully request that the Honorable Council authorize an application and amended budget to the Local Waterfront Revitalization Plan (LWRP) program.

Thank you for your consideration. Please let me know if you have any questions or require any additional information.

Sincerely,

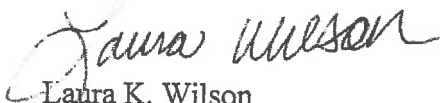

Laura K. Wilson

Director of Community Development



CFO. A

JUL 19 2022

June 7th, 2022

Honorable Austin J. Tylec, Mayor
Common Council Members
City Hall
216 Payne Avenue
North Tonawanda, NY 14120

RE: Labor Day Concert

Dear Honorable Body,

The Oliver Street Merchants Association is requesting the approval from the Common Council for Oliver Street's first annual "Labor Day" concert on September 4th from 3-10 pm. We request the closing of Oliver Street from 9th to 11th Avenue, traffic will still be able to turn left on Oliver Street from 9th Street. This festival will include a Car show, Artisan vendors as well as, four popular local bands. The Artisan vendors will be located down and around Buffalo Bolt Parkway, the stage located at the center of Oliver and 10th and the Car show between 10th and 11th Avenue.

We are going to "adopt" a WNY Hero and collaborate with WNY Heroes, we are anticipating kicking off the concert with the Honor Guard followed by the series of bands. We also request the support of the Police Auxiliary to ensure the safety of the patrons of this event. As well as, additional garbage cans for trash refuse.

I look forward to answering any questions that the Council may have and look forward to seeing you all there-

Sincerely,

Lauren Schulte
President
Oliver Street Merchants Association, Inc.

RECEIVED
CITY CLERK'S OFFICE

2022 JUL 6 PM 12:33
NORTH TONAWANDA NY

CFO. B

Date: 7/8/2022

JUL 19 2022

The Honorable Body
216 Payne Ave
North Tonawanda
New York 14120

A successful and well-received event is being proposed again to help homeless dogs right here in North Tonawanda and bring our residents - and their four-legged friends - together.

From noon to 4 p.m. Saturday, Sept. 3 at Carruthers Park, I would like to host a free community event called "Dogs are People, Too." with the assistance of Mayor Tylec.

The event would give residents an opportunity to visit a park that is not as well-known, bringing eyes to it from guests across WNY; learn more about fostering and adopting through Diamonds in the Ruff Animal Rescue; spread awareness about keeping pets safe; and offer the opportunity for residents to register their pet in North Tonawanda which helps when the pet is lost.

We would also invite food trucks; have music; activities for residents to enjoy with their dogs like a free ball pit photo shoot with Tailor Mayde Photography; a doggy fashion show; dog pools; doggy kissing booth; opportunities to learn about the North Tonawanda Police K9s; appearances from WNY Heroes service dogs; possible Paw Patrol characters for kids; dog-themed vendors with dog treats, bandanas, collars, leashes, etc.; a basket raffle for Diamonds in the Ruff and more.

As a proud North Tonawanda resident, and creator of Sweet Buffalo, I wanted to continue the dog event in our city because I believe residents truly enjoy it - but even more so that their dogs enjoy!

Dogs must always remain leashed to attend the event.

Thank you,
Kim Larussa
Sweet Buffalo
kimberlylarussa@aol.com

2022 JUL 13 AM 8:08
NORTH TONAWANDA NY

RECEIVED
CITY CLERK'S OFFICE

CFO-C

JUL 19 2022

Joseph Reiller
1126 Marcia Drive
North Tonawanda, NY 14120
716-545-6523

North Tonawanda Athletic Association
1261 Strad Avenue
North Tonawanda, NY 14120

Dear honorable members of the North Tonawanda City Council,

The North Tonawanda Athletic Association is an organization that aims at bonding and creating a positive environment for the youth in our city. As part of our community initiatives, we hold fundraising events to maintain our tight budgetary limits.

This year, we would like to hold a boot drive at our local farmer's market on Market Drive. It shall take place July 30, 2022 from 8:00am until 1:00 pm. We are kindly asking permission for this event to take place.

Your timely response to this request would be greatly appreciated. I look forward to positive feedback from your esteemed members.

Thank you and regards,
Joseph Reiller
Board Member and Coach

2022 JUL 14 AM 11:58
NORTH TONAWANDA NY

RECEIVED
CITY CLERK'S OFFICE